

**Vorschubeinheiten**

**Technische Daten**

**Feed units**

**Technical data**

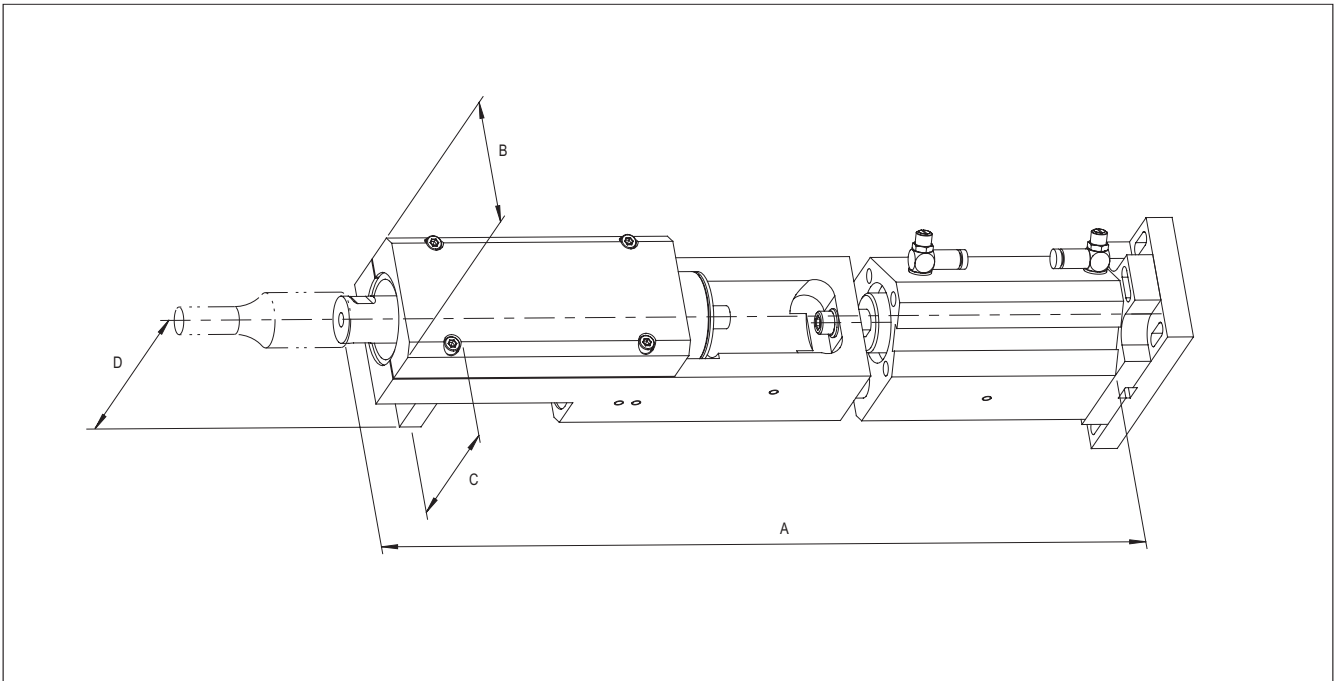

Nachfolgend sind die Schweißkräfte, sowie die Abmessungen unserer Standardvorschubeinheiten in Abhängigkeit der Ultraschall-Frequenz (35, 30 und 20 kHz) und des Zylinderdurchmessers aufgeführt. Detaillierte Informationen senden wir Ihnen auf Anfrage gerne zu.

Shown below are the welding forces, as well as the dimensions of our standard feed units in relation to ultrasonic frequency (35, 30 and 20 kHz) and cylinder diameter. We will be pleased to send you detailed information on request.

Schweißkraft [N] Welding forces [N]			
Druck [bar] Pressure [bar]	Zyl.-Ø [mm] Cyl.-Ø [mm]		
	Ø 32	Ø 50	Ø 63
1	72	177	281
2	145	353	561
3	217	530	842
4	290	707	1.120
5	362	884	1.400
6	434	1.060	1.680

Zyl.- Ø Cyl.- Ø	VE 35					VE 30			VE 20			
	Ø 32					Ø 50			50		63	
Hub Stroke	60	80	100	125	150	30	100	125	80	100	125	100
A	355.5	375.5	395.5	420.5	445.5	403.5	473.5	498.5	488.5	508.5	533.5	523
B	58	58	58	58	58	64	64	64	88	88	88	88
C	75.5	75.5	75.5	75.5	75.5	117	117	117	117	117	117	118.5
D	49,5	49,5	49,5	49,5	49,5				75,5	75,5	75,5	75,5