

Feed units
Type VE 35, VE 30 and VE 20
Special designs for building special machines

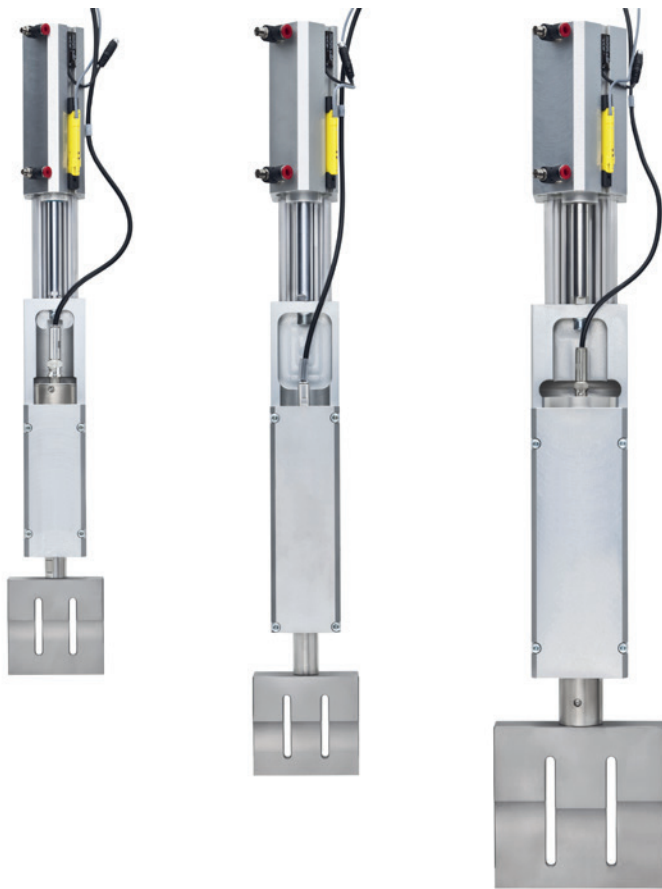

Feed units type VE 35, VE 30 and VE 20

The universal standard for building special machines

The VE 35, VE 30 and VE 20 feed units are used to fix an ultrasonic welding stack. Feed units are used mainly in the building of special machines in sectors such as the car industry or other plastics processing industries, the textile industry, as well as in the building of packaging machinery and in the food industry. They can be simply incorporated in existing or new machine concepts for various different applications.

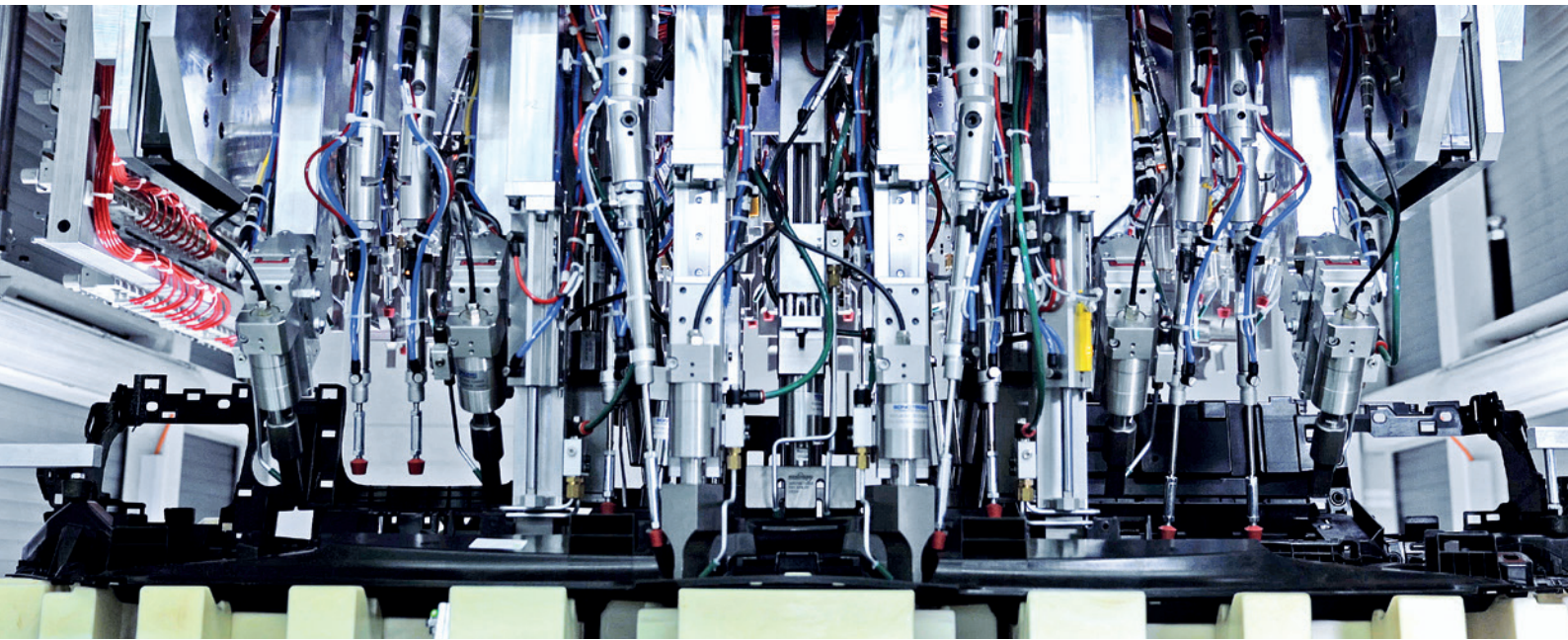

As ultrasound specialists we ourselves use our feed units when building special machines and have perfected them from our own experience. Our feed units achieve their durability as a result of outstanding workmanship and high-quality precision guides.

SONOTRONIC offers feed units for welding stacks having ultrasonic frequencies of 35, 30 and 20 kHz. The maximum welding forces are achieved at 20 kHz frequency and the largest dimensions can be handled. The available diameters and stroke lengths of the feed units are governed in each case, by the sound frequency.

Properties and advantages

- Precise monitoring of the welding path:
 - Analogue displacement measuring system using a Hall-effect sensor (accuracy 0.05 mm)
 - Depth adjustments by control panel
- Precise feed into the welding position:
 - X-Y adjustment +/- 5 mm
 - Basic position sensing via a Reed switch with LED
 - Hardened guide shafts
 - Ball sockets
- Precision build-up of welding force:
 - Max. operating pressure: 10 bar
 - Magnet ring piston
- Housing (natural aluminium)
- Simple integration into existing or new machine concepts

Applications

- Ultrasonic
 - Welding
 - Cutting
 - Cut & seal
 - Punching
 - Riveting
 - Embossing
- Special machine building

Sectors

- Car industry
- Plastics processing industries
- Textile industry
- Packaging industry
- Food industry



Infos online

Technical data

Dimensions and cylinder diameter

Shown below are the welding forces, as well as the dimensions of our standard feed units in relation to ultrasonic frequency (35, 30 and 20 kHz) and cylinder diameter. We will be pleased to send you detailed information on request.

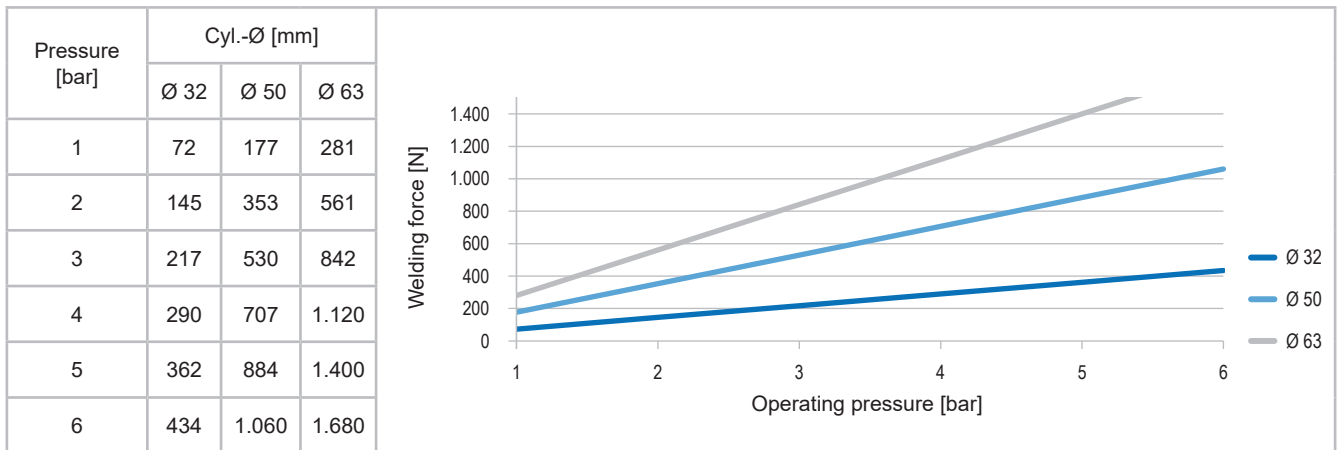
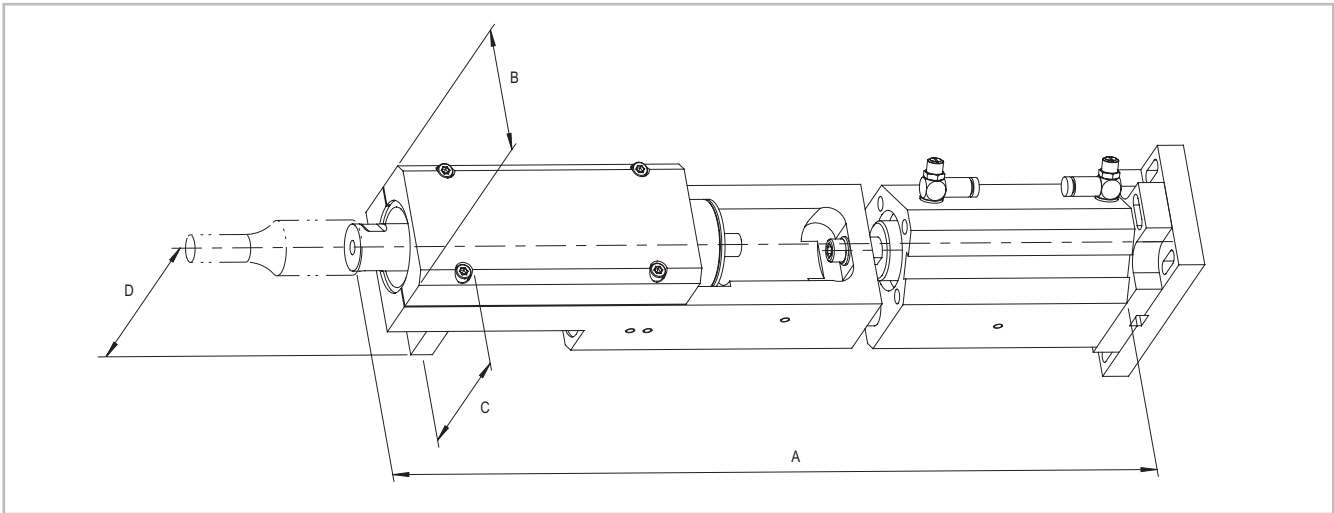

| Cyl.-Ø | VE 35 (35 kHz) | | | | | VE 30 (30 kHz) | | | VE 20 (20 kHz) | | | |
|--------|----------------|-------|-------|-------|-------|----------------|-------|-------|----------------|-------|-------|-------|
| | Ø 32 | | | | | Ø 50 | | | Ø 50 | | Ø 63 | |
| Stroke | 60 | 80 | 100 | 125 | 150 | 30 | 100 | 125 | 80 | 100 | 125 | 100 |
| A | 355,5 | 375,5 | 395,5 | 420,5 | 445,5 | 403,5 | 473,5 | 498,5 | 488,5 | 508,5 | 533,5 | 523 |
| B | 58 | 58 | 58 | 58 | 58 | 64 | 64 | 64 | 88 | 88 | 88 | 88 |
| C | 75,5 | 75,5 | 75,5 | 75,5 | 75,5 | 117 | 117 | 117 | 117 | 117 | 117 | 118,5 |
| D | 49,5 | 49,5 | 49,5 | 49,5 | 49,5 | 76 | 76 | 76 | 76 | 76 | 76 | 76 |



Infos online

Special design feed units

Development specific to requirements for optimum ultrasonic results

Particularly when building special machines, special solutions regarding the design of the feed units are required in certain cases. If, for example, welding areas are difficult to access, space is limited or if extreme height differences have to be overcome between welding points, then standard feed units cannot be used.

For such situations, SONOTRONIC develops appropriate feed units to meet the requirements of customer and application. With our many years of experience in building special ultrasonic machines, we will find a solution to every problem and the perfect feed unit for every task.

Examples of special solutions

- Where space is limited
 - Compact feed unit
 - Short-stroke feed unit
 - Feed unit 35 in narrow design (converter width)
- For welding points that are difficult to access
 - Return stroke feed unit
 - Angle feed unit
- For extreme height differences
 - Tandem feed unit with two separate welding stacks



08-2023 © SONOTRONIC GmbH • Subject to change.



SONOTRONIC GmbH
 Headquarters
 Becker-Goering-Str. 17-25
 76307 Karlsbad, Germany
 Phone: +49 7248 91 66-0
 Fax: +49 7248 91 66-144
 info@sonotronic.de
 www.sonotronic.de

SONOTRONIC, Inc.
 Branch USA
 31132 Century Drive
 Wixom, MI 48393, USA
 Phone: +1 248 987 5970
 Fax: +1 248 987 5964
 info@sonotronic.com
 www.sonotronic.com

Linked with success.

Industry solutions

- Automotive
- Plastics
- Packaging & Food
- Technical Textiles
- Environmental

Products

- Special machines
- Standard machines
- Ultrasonic systems
- Ultrasonic components

Technologies

- Ultrasonic
- Infrared
- Hot plate
- Hot air



CLIMATE NEUTRAL COMPANY

Trough compensation of climate protection certificates. Certified by Fokus Zukunft.

